



CUTLINE™

AG250V

Above Ground Mulcher

- **Variable Motors**
- **Dependable**
- **Productive**
- **Rugged**





PRODUCT FEATURES

FRAME

HIGH STRENGTH STEEL CONSTRUCTION

- BREAKER MULCH BARS
- MULCH CONTROL CURTAIN
- MULTIPLE MAINTENANCE ACCESS POINTS
- DURABLE SHOE PADS

POWERTRAIN

- DUAL-REXROTH™ 160CC VARIABLE MOTORS
- GATES POLLYCHAIN DRIVE CHAIN (NO-SLIPPAGE)
- ADJUSTABLE BELT TENSIONER
- IMPERIAL HOSE/FITTINGS, FASTENERS

DRUM

- 8 FT (2.5 METER) CUT WIDTH
- SOLID OR HOLLOW DRUM
- 56 FAET™ TYPE 2 CARBIDE TEETH
- CENTER CUT FEATURE (PULLS WOOD TO CENTER)

BRUSH BAR

- STRONG, RIGID, BUSHING MOUNTED
- INTERCHANGEABLE RAKES FOR FALLEN DEBRI CLEANUP
- 49 DEGREE TILT, (WITH MOUNTING BRACKET)
- HEAVY DUTY 3" BORE CYLINDERS

MOUNTING BRACKET

- MULTI-PURPOSE ATTACHMENT BRACKET DESIGNED FOR CUSTOM OR REGISTERED OEM SOLUTIONS
- 35 DEGREE AXIAL/ROTATIONAL CONTROL
- 4" HYDRAULIC TILT CYLINDERS

WEIGHT: HEAVY DUTY DRUM 8270 LBS (3759 KG)
 STANDARD DUTY DRUM 6273 LBS (2851 KG)

MADE IN CANADA. PARTS STOCKED AT LOCAL SERVICE DEPOTS THROUGH OUT NORTH AMERICA.

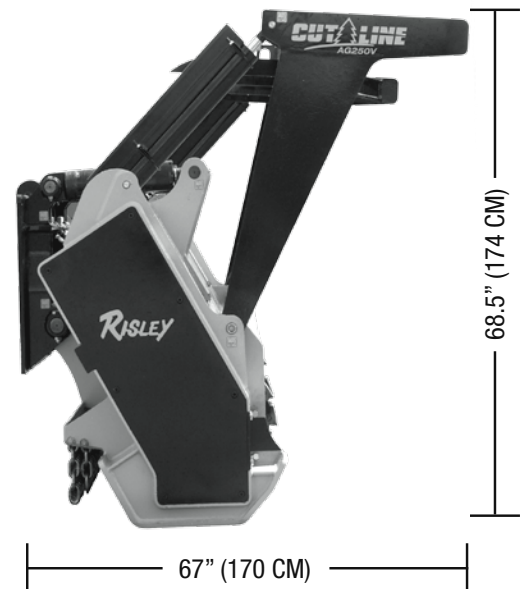
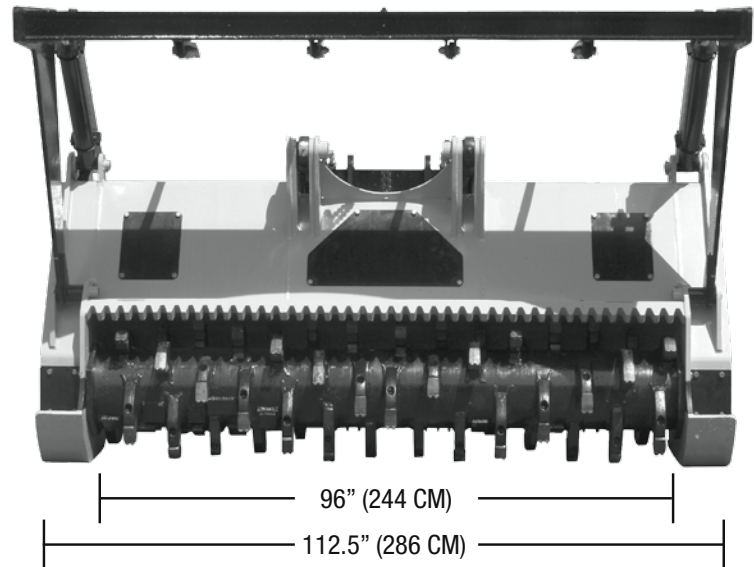

STEP AHEAD™

CALL 1-780-532-3282 OR TOLL FREE 1-866-783-7243
OR VISIT US ONLINE AT WWW.RISLEYEQUIPMENT.COM

PRINTED IN CANADA. SPECIFICATIONS SUBJECT TO CHANGE WITHOUT NOTICE.

AG250-090527A